

DIMENSION SHEET

Ref : 00047
 Date : 11/06/02
 Issue : B
 Page : 1 of 1

Input/Output Reactors suitable for L100 Inverters

Hitachi Inverter	Suitable Choke	A	B	C	D	E	Weight in Kg
L100 002 NFE	RL00402	112	102	74	50	36	2.3
L100 004 NFE	RL00402	112	102	74	50	36	2.3
L100 005 NFE	RL00402	112	102	74	50	36	2.3
L100 007 NFE	RL00402	112	102	74	50	36	2.3
L100 011 NFE	RL00802	152	122	79	54	50	3.2
L100 015 NFE	RL00802	152	122	79	54	50	3.2
L100 022 NFE	RL01202	152	122	79	54	50	4.5
L100 004 HFE	RL00202	112	102	74	50	36	1.8
L100 007 HFE	RL00202	112	102	74	50	36	1.8
L100 015 HFE	RL00403	112	102	79	54	36	1.8
L100 022 HFE	RL00803	152	122	86	63	50	5.0
L100 030 HFE	RL00802	152	122	79	54	50	3.2
L100 040 HFE	RL01202	152	122	79	54	50	4.5
L100 055 HFE	RL01202	152	122	79	54	50	4.5
L100 075 HFE	RL01802	152	122	86	53	50	5.4

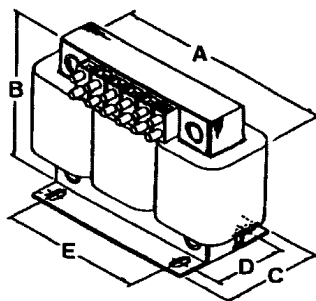

HID LTD

Vantage House, Harfreys Road, Great Yarmouth, Norfolk, NR31 0LS
 Tel: 01493 442525 Fax: 01493 442323 Email: sales@hid.co.uk Website: www.hid.co.uk